



## CRST4120

尺寸(Dimensions):26.8X21.5X22.3mm

Open type:24X19X20mm

## 特点 Features

- 1,体积小,触点负载大,可承受大冲击电流 40A/14VDC  
Small Size,heavy contact load,capable of standing strong current of 40A/14VDC.
- 2,可直接焊接在印刷线路板中.PCB mounting.
- 3,有适用于欧洲的 11mm 脚距和适用于美国的 8mm 脚距.  
Both European 11mm pole distance and American 8mm pole distance available.
- 4,供自动控制设备,汽车待使用. Suitable for automatic control facilities and automobile application etc.

## 订货信息 Ordering information

CRST 4120--C-S-DC12V--L

1 2 3 4 5

- 1,型号 Part number: CRST4120U,CRST4120E
- 2,触点形式 Contact arrangement:A:1A;B:1B;C:1C
- 3,封装形式:S:试水式;O:无外壳 Enclosure: S:Sealed type; O:Open type.
- 4,线圈额定电压 Coil rated voltage(V):DC:6,9,12,24
- 5,线圈功耗 Coil power consumption L:1.6W;Nil:1.9W

## 触点数据 Contact data

触点形式 Contact Arrangement	1A(1H)(SPST NO);1B(SPST NC);1C(1Z)(SPDT)	
触点材料 Contact Material	AgNi, AgSnO <sub>2</sub> , AgCdO	
触点负载(阻性) Contact Rating(Resistive)	1A(40A/14VDC) 1B(30A/14VDC)	
最大切换功率 Max.Switching Power	630W 2400VA	
最大切换电压 Max.Switching Voltage	75VDC 380VAC 最大切换电流 Max.Switching Current:45A	
触点阴性或压降 Contact Resistance or Voltage Drop	≤30mΩ	
寿命 Operation Life	电气 Electrical	10 <sup>5</sup>
	机械 Mechanical	10 <sup>7</sup>

## 线圈参数 Coil Parameter

线圈电压 Coil voltage (VDC)		线圈电阻 Coil Resistance Ω ±10%	吸合电压 VDC(最大) Pick up Voltage VDC(Max) (额定电压的 70%) (70% of rated voltage)	释放电压 VDC Release voltage VDC(Min) (额定电压的 10%) (10% of rated voltage)	线圈功耗 Coil power consumption (W)	动作时间 Operate Time (mS)	释放时间 Release Time (mS)
额定 Rated	最大 Max						
6	7.8	19	4.20	0.6	1.9	≤5	≤3
9	11.7	42.6	6.30	0.9			
12	15.6	90	8.40	1.2	1.6		
24	31.2	360	16.8	2.4			

注意:1,使用的线圈电压低于线圈额定电压时将会损害继电器的工作.

2,吸合,释放电压仅供检测用,不是设计的使用指标.

Caution:1,The use of any coil voltage less than the rated coil voltage will compromise the operation of the relay.

2,Pick up and release voltage are for test purposes only and are not be used as design criteria.

## 技术特性 Operation condition

绝缘电阻 Insulation Resistance	最小 100MΩ min(at 500VDC)
介质耐压 Dielectric Strength	
断开触点间 Between Contacts	50Hz 500V
触点与线圈间 Between Contacts and Coil	50Hz 750V
耐冲击 Shock Resistance	100m/s <sup>2</sup> 11ms
抗振性 Vibration Resistance	10~40Hz 双振幅 Double amplitude 1.27mm
引出端强度 Terminals Strength	10N
可焊性 Solderability	235±2℃ 3±0.5s℃
环境温度 Ambient Temperature	-40~125℃
相当湿度 Relative Humidity	85%(at 40℃)
质(重)量 Mass	19g(Open type) 21g

## 外形尺寸 Dimensions(mm/Inch)

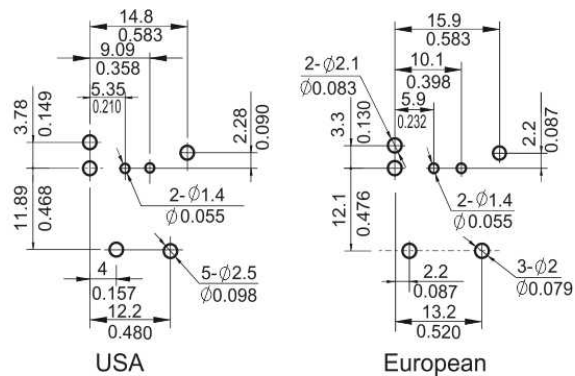
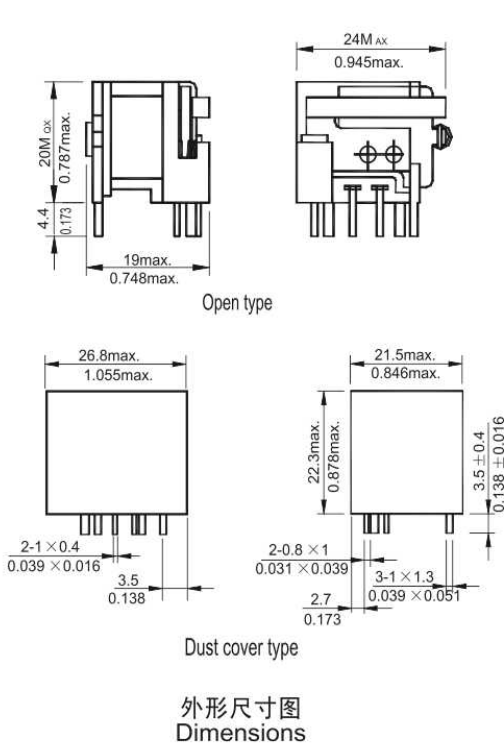

安装尺寸图 (底视图)  
Mounting (Bottom view)

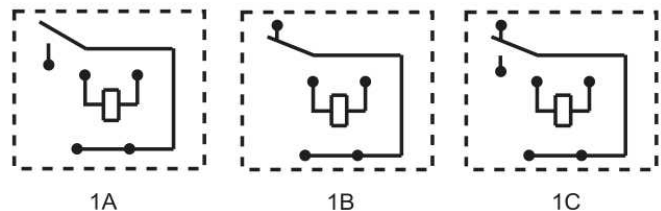

接线图 (底视图)  
Wiring diagram (Bottom view)

注: 1) 尺寸以毫米为单位。  
NOTES Dimensions are in millimeters.

2) 给出的等量英寸值仅供参考。  
Inch equivalents are given for general information only

## 参考数据 Reference Data

